



INSTRUCTION MANUAL

MT390

MULTIFUNCTION INSTALLATION TESTER



1. Safety.....	4
1.1. Safety Considerations.....	4
1.2. Safety Symbols.....	4
1.3. Terminology.....	4
1.4. Caution.....	4
1.5. Warnings.....	5
1.6. Declaration of Conformity.....	5
1.7. Error Codes.....	6
2. Specifications.....	6
2.1. Specifications.....	6
2.2. Insulation.....	8
2.3. General Specifications.....	8
3. Instrument Overview.....	9
3.1. Front View.....	9
3.2. Connector Panel.....	10
3.3. Battery & Fuse.....	11
3.4. Understanding the Display.....	12
4. How to use the Tester.....	14
4.1. Important Symbols & Messages during the Measurement Description.....	14
4.2. Using the Loop/PFC Function.....	17
4.3. Using the RCD Function.....	21
4.4. Using the Voltage Function.....	25
4.5. Using the Phase Sequence Function.....	26
4.6. Voltage/Phase Function Menu Operation.....	27
4.7. Using the Insulation Function.....	27
4.8. Using the RF Function.....	28
4.9. Using the Low Ohm Function.....	29
5. Menu.....	31
6. System Settings.....	31
6.1. Languages.....	32
6.2. Date/Time.....	32
6.3. TV.....	32
6.4. Memory.....	33
6.5. Auto Screen Off.....	33
6.6. Auto Power Off.....	33
6.7. System Default Settings.....	34
6.8. System Upgrade.....	34
7. Run Settings.....	34
7.1. Bluetooth.....	35
7.2. Data Record.....	35
7.3. Datalog.....	36
8. Data Record.....	36
8.1. Delete Files.....	36
8.2. Data Record Preview.....	37
8.3. Menu.....	37
8.4. Drawing.....	38
8.5. Datalog Colour.....	38

1. SAFETY

WARNING: You must read and completely understand the Safety Considerations part of this manual before using the instrument.

1.1. SAFETY CONSIDERATIONS

- This manual contains instructions regarding the safe use and the proper functioning of the instrument.
- If not complied with, the user could be exposed to danger and the instrument to possible damage.

1.2. SAFETY SYMBOLS



WARNING!



CAUTION! Voltage Present



Earth



Double Insulation [Class II insulation]



Fuse



Prohibited to use for the Electrical System which uses the voltage above 550V



Conformity to European Standards

1.3. TERMINOLOGY

- The term **WARNING** as used in this manual defines a condition or a procedure which could lead to a serious injury or accident.
- The term **CAUTION** defines a condition or action which could lead to the instrument being rendered defective during the testing process.

1.4. CAUTION

Do not change functions on the test instrument with the test leads in place, i.e. changing from a "dead test" to a test where the supply is required could damage the instrument.

1.5. WARNINGS

- Make sure to read and fully understand the instruction contained within this manual prior to use.
- This instrument is not intrinsically safe therefore do not use the instrument in hazardous environments.
- In order to prevent fire and/or electrical shock, do not use the instrument in wet, damp or highly humid environments.
- Prior to use, check if the instrument functions correctly, if any symptoms/symbols of malfunction or abnormalities are indicated, do not use and inform your supplier.
- Users who could be exposed to voltages in excess of the extra low band (50V AC or 120V DC) should be competent and be aware of the requirements of the relevant IEC Standards regarding the use of the instrument and the associated leads and probes etc.
- Make sure your fingers holding the test probes are positioned behind the safety lines of the test probes.
- Do not open the instrument.
- If the internal fuse (protective device) blows, replace with a device of the same type and rating, if it blows again seek professional advice, do not replace fuse and try again.
- When carrying out the "dead tests" ensure prior to connection of the instrument leads the circuit under test has been confirmed "dead" and secured in the OFF position using appropriate methods.
- Battery condition is indicated by a beep, check and replace if necessary.
- Do not test an electrical circuit or systems where the voltage is in excess of 550V.
- Ensure at all times the leads are in compliance with the IEC and CAT Ratings (as supplied) and not damaged.

1.6. DECLARATION OF CONFORMITY

- This instrument has been tested according to the below regulations:
- EN 61326: Electrical equipment for measurement, control and laboratory use.
- EN 61010-1: Safety requirements for electrical equipment for measurement, control and laboratory use-Part 1:

General requirements:

- BS EN61557: Electrical safety in low voltage distribution systems up to 1000V AC and 1500V DC.
- Equipment for testing, measuring or monitoring of protective measures.
- Part 1 General requirements
- Part 2 Insulation resistance
- Part 3 Loop resistance
- Part 4 Resistance of earth connection and equipotential bonding
- Part 6 Residual current devices (RCDs) in TT and TN systems
- Part 7 Phase sequence
- Part 10 Combined measuring equipment

1.7. ERROR CODES

- Various error conditions are detected by the tester and are indicated with the icon, "Err", and an error number on the primary display.
- These error conditions disable testing and, if necessary, stop a running test.

Error Condition Code	Code	Solution
Solution Fault Voltage	1	Check the installation, in particular, the voltage between N and PE.
Over Temp	2	Wait while the tester cools down.
Excessive Noise	3	Switch off all appliances (Loop, RCD measurements) and move the earth stakes (earth measurement).
Excessive Probe Resistance	4	Put the stakes deeper into the soil; Tamp down the soil directly around the stakes; Pour water around the stakes but not at the earth ground under test.
Self Test Fails	5	Return the tester to a Service Center.

2. SPECIFICATIONS

2.1. SPECIFICATIONS

Function	Range	Resolution	Accuracy
LOOP Resistance L- PE (Hi-Amp)	0.23 to 9.99 Ω	0.01 Ω	\pm (4% of reading + 6 digits)
	10.0 to 99.9 Ω	0.1 Ω	
	100 to 999 Ω	1 Ω	

Measuring Current: 8.0A to 25.0A.

Range of the Voltage Used: 195VAC to 260VAC (50,60Hz).

Function	Range	Resolution	Accuracy
LOOP Resistance L- PE (No Trip)	0.23 to 9.99 Ω	0.01 Ω	\pm (5% of reading + 6 digits)
	10.0 to 99.9 Ω	0.1 Ω	
	100 to 999 Ω	1 Ω	

Measuring Current: <15mA.

Range of the Voltage Used: 195VAC to 260VAC (50,60Hz).

Function	Range	Resolution	Accuracy
LINE Resistance L- N	0.23 to 9.99Ω	0.01Ω	±(4% of reading + 6 digits)
	10.0 to 99.9Ω	0.1Ω	
	100 to 999Ω	1Ω	

Measuring Current: 8A to 25.0A.

Range of the Voltage Used: 195VAC to 260VAC (50,60Hz).

Function	Range	Resolution	Accuracy
PFC/PSC	0 to 10kA	1A	
	0 to 50kA	1A	

Earth Fault Current (PFC).

Short Circuit Current (PSC).

Determined by accuracy of loop resistance and mains voltage measurements.

RCD (BSEN 61557-6)							
RCD Rating	10mA	30mA	100mA	300mA	500mA	650mA	1A
Voltage Range	220V±10% (45Hz to 65Hz)						
Accuracy of the Current of the RCD	Δn, 2* Δn, 5* Δn: (0% + 10%)						
	1/2* Δn: -10% to 0%						
Range of the Timing of the RCD	1/2* Δn: 0mS to 2000mS						
	1* Δn: 0mS to 300mS						
	2* Δn: 0mS to 150mS						
	5* Δn: 0mS to 40mS						
Resolution of the RCD Timing	0.1ms						
Accuracy of the Timing of the RCD	±(5%+5)						
Accuracy of the Current of the RCD	±(10%+4)						

Function	Range	Resolution	Accuracy
AC Voltage	80 to 500V	1V	±(2% of reading + 2 digits)
Frequency	45 to 65Hz	1 Hz	±2Hz
Low Ohm	0.000 to 2.000Ω	0.001Ω	±(1.5% of reading + 30 digits)
	2.00 to 20.00Ω	0.01Ω	±(1.5% of reading + 3 digits)
	20.0 to 200.0Ω	0.1Ω	
	200 to 2000Ω	1Ω	±(1.5% of reading+ 5 digits)

Max. Open Circuit Voltage: 5.0V ± 1V DC.

Overload Protection: 250V RMS.

Earth Resistance	0.00 to 99.99Ω	0.01Ω	±(2% of reading + 30 digits)
	100.0 to 999.9Ω	0.1Ω	±(2.5% of reading+ 6 digits)
	1000 to 2000Ω	1Ω	

2.2. INSULATION

Terminal Voltage	Range	Resolution	Test Current	Short Circuit Current
125V (0%~+10%)	0.125~4.000M Ω	$\pm(3\%+10)$	1mA at load 125k Ω	$\leq 1\text{mA}$
	4.001~40.00M Ω	$\pm(2\%+10)$		
	40.01~400.0M Ω	$\pm(4\%+5)$		
	400.1~1000M Ω	$\pm(5\%+5)$		
250V (0%~+10%)	0.250~4.000M Ω	$\pm(3\%+10)$	1mA at load 250k Ω	$\leq 1\text{mA}$
	4.001~40.00M Ω	$\pm(2\%+10)$		
	40.01~400.0M Ω	$\pm(3\%+2)$		
	400.1~1000M Ω	$\pm(3\%+2)$		
500V (0%~+10%)	0.500~4.000M Ω	$\pm(3\%+10)$	1mA at load 500k Ω	$\leq 1\text{mA}$
	4.001~40.00M Ω	$\pm(2\%+10)$		
	40.01~400.0M Ω	$\pm(3\%+2)$		
	400.1~1000M Ω	$\pm(4\%+5)$		
1000V (0%~+10%)	1.000~4.000M Ω	$\pm(3\%+10)$	1mA at load 1M Ω	$\leq 1\text{mA}$
	4.001~40.00M Ω	$\pm(2\%+10)$		
	40.01~400.0M Ω	$\pm(3\%+2)$		
	400.1~1000M Ω	$\pm(4\%+5)$		

2.3. GENERAL SPECIFICATIONS

Function	Range
Power Source	8x 1.5V AA Size Alkaline batteries or 8x 1.2V AA Size rechargeable Ni-MH batteries
Battery Life	Average of 15 hours
CAT Rating	CAT III 600V
Protection Classification	Double Insulation
Protection Rating	IP65
LCD Screen Type	3.5" TFT
Pixels	320 x 240
Operating Temp	0 to 45°C; 95% at 10°C to 30°C: Non-condensing
Relative Humidity	75% at 30 to 40°C
Storing Temp	-10 to 60°C
Operating Altitude	2000m
Protective Device	500mA Fast response BS 88 Fuse
Dimensions (L x W x H)	24.2 x 10.5 x 14.5cm
Weight	1.56kg

3. INSTRUMENT OVERVIEW

3.1. FRONT VIEW

1 - TEST Button

- The TEST Button is surrounded by a "Touch Pad".
- The touch pad measures the potential between the operator and the tester's PE terminal.
- If you exceed a 100V threshold, the D symbol above the touch pad is illuminated.

2 - Warning Lamp

3 - Navigation Button

4 - Lanyard Hole

5 - F1/F2/F3/F4 Software Button

6 - 320x240 (RGB) Colour Active Matrix

7 - HELP Button

8 - POWER/ESC Button

9 - Function Selector Switch

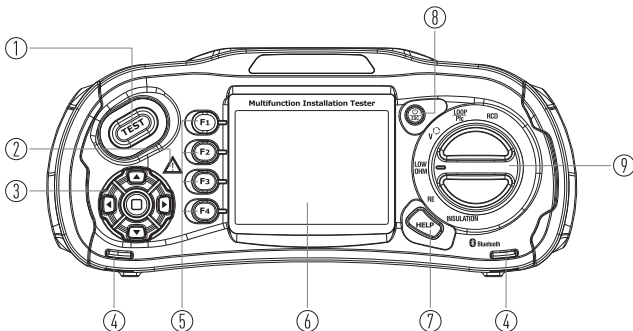

3.2. CONNECTOR PANEL

- 1 - Input Terminal to Operate the Switched Probe
- 2 - Line Input
- 3 - Protective Earth Input
- 4 - Neutral Input
- 5 - Input Terminal to Operate the Switched Probe
- 6 - TV OUT
- 7 - System Reset
- 8 - USB Connector
- 9 - Micro SD Card Slot
- 10 - Power Supply Socket

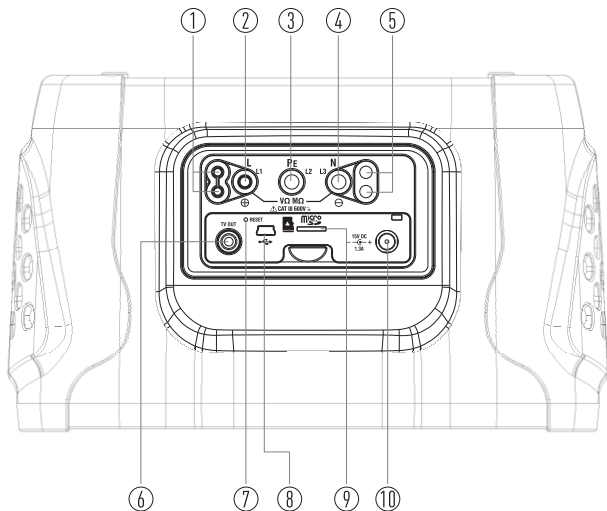

3.3. BATTERY & FUSE

- 1 - Battery Cover
- 2 - Fuse 5A/600V
- 3 - Fuse 5A/600V
- 4 - Fuse 500mA/600V
- 5 - Battery Cells (Size AA)

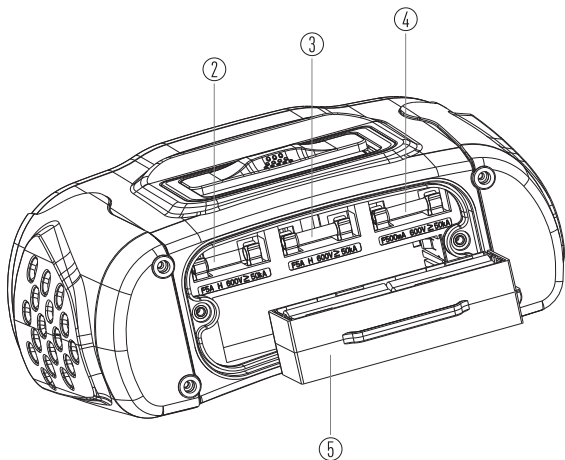
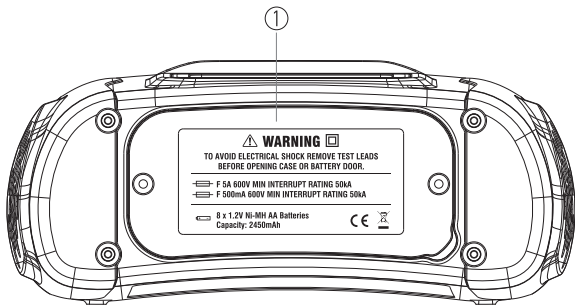



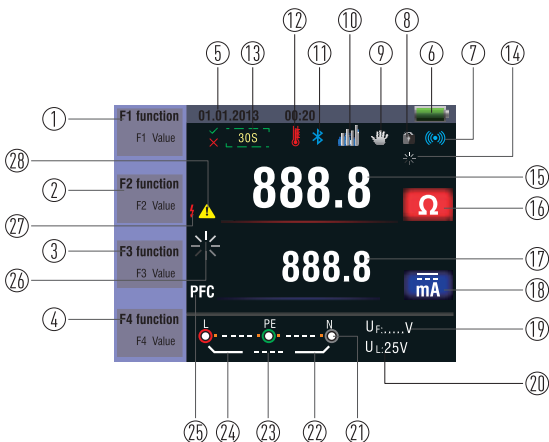



















3.4. UNDERSTANDING THE DISPLAY





No.	Annunciator	
	Function	Value
1	RCD	AUTO
		x1/2
		x1
		x2
		x5
		RAMP
	Loop/PFC	LL-PE
		L-L
		L-N
	V/Phase	L-PE

No.	Annunciator	
	Function	Value
1	Continuity	0.5Ω
		1.0Ω
		2.0Ω
		5.0Ω
		10.0Ω
		20.0Ω
		50.0Ω
		50.0Ω
	Terminal Voltage	125V
		250V
	500V	
	1000V	

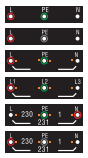
No.	Annunciator	
	Function	Value
2	Trip Current	30mA
		100mA
		300mA
		500mA
		650mA
		1000mA
		10mA
Current	NO Trip	
	Hi Amp	
Beeper	OFF	
	ON	
3	Type of RCD	 G  S
	Lock	OFF ON
4	0°/180°	0° 180°
	ZERO	
	Reference	0.125MΩ
		0.25MΩ
		0.5MΩ
		1MΩ
		2MΩ
		5MΩ
		10MΩ
		20MΩ
		50MΩ
100MΩ		
200MΩ		
5	Date/Time	

No.	Annunciator	Meaning
6		Low battery icon See Indicates the battery status.  100%  80%  50%  20%  Low Battery. for additional information on batteries and power management.
7		Beeper.
8		Lock.
9		Hold.
10		Datalog.
11		Bluetooth.
12		Appears when the instrument is overheated.
13		Display 30 seconds (time-delayed).
14		Being tested.
15		Primary display and measurement units.
16		Primary display and measurement units.
17		Primary display and measurement units.
18		Primary display and measurement units.
19		Fault Voltage, measures neutral to earth.
20		Indicates the preset fault voltage limit.
21		Arrows above or below the terminal indicator symbol indicates reverse polarity. Check the connection or check the wiring is correct.
22	N-PE	N-PE Value.
23	L-N	L-N Value.
24	L-PE	L-PE Value.

No.	Annunciator	Meaning
25	PFC	Prospective Earth Fault Current. Calculated from voltage and loop impedance which is measured line to protective earth.
	PSC	Prospective Short Circuit. Calculated from measured voltage and impedance when reading line to neutral.
26		Being tested
27		High Voltage Warning
28		Warning



4. HOW TO USE THE TESTER

4.1. IMPORTANT SYMBOLS AND MESSAGES DURING THE MEASUREMENT DESCRIPTION

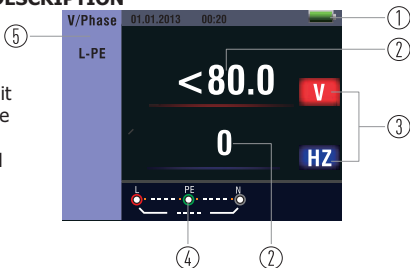
- 1 - Battery status
- 2 - Displayed measured value
- 3 - The measurement unit of the measured value
- 4 - The indication of the correct input terminal connection
- 5 - Displayed menu







4.1.1. Displayed Icons (Symbols) & Messages in Voltage Function

	Indicates the correct input terminal connectivity, the user should connect the test leads to the appropriate terminals.
	Indicates L connection is connected on the N input terminal and vice-versa.
	Indicates no connection on the PE input terminal.



Notes:

- If the wiring condition is other than normal, the Tester is limited on its measurements that can be performed.
- Will not detect two hot wires in a circuit.
- Will not detect a combination of defects.
- Will not detect reversal of grounded and grounding conductors.

Indicates the Battery Status

	100%
	80%
	50%
	20%
	Low Battery.







4.1.2. Displayed Icons (Symbols) & Messages in LOOP/PFC Function

	Indicates the correct input terminal connectivity, the user should connect the test leads to the appropriate terminals.
	Indicates L connection is connected on the N input terminal and vice-versa.
	Indicates no connection on the PE input terminal.

Notes:

- If the wiring condition is other than normal, the Tester is limited on its measurements that can be performed.
- Will not detect two hot wires in a circuit.
- Will not detect a combination of defects.
- Will not detect reversal of grounded and grounding conductors.

Indicates the Battery Status

	100%
	80%
	50%
	20%
	Low Battery.
	Indicates high temperature and therefore cannot make any measurements



Message:

Measuring: Function in use - measurement being carried out.

RCD Trip: During the measurement, the RCD has tripped therefore no test result obtained.

Noise: Appears during the No Trip Loop Measurement, and indicates that the displayed value may not be accurate due to "mains" interference-test to be repeated.







4.1.3. Displayed Icons (Symbols) and Messages in RCD Function

	Indicates the correct input terminal connectivity, the user should connect the test leads to the appropriate terminals.
	Indicates L connection is connected on the N input terminal and vice-versa.
	Indicates no connection on the PE input terminal.

Notes:

- If the wiring condition is other than normal, the Tester is limited on its measurements that can be performed.
- Will not detect two hot wires in a circuit.
- Will not detect a combination of defects.
- Will not detect reversal of grounded and grounding conductors.

Indicates the Battery Status

	100%
	80%
	50%
	20%
	Low Battery.
	Indicates high temperature and therefore cannot make any measurements

Message:

- Half: Appears during the auto test when red has operated on the x 1/2 test.
- Half Trip: Appears during the manual test when red has operated on the x 1/2 test.
- UL OVER: Appears when UF voltage exceeds the previously set UL voltage. (UL voltage can be set to 25V or 50V) The user must check the impedance between L-PE.

4.1.4. Displayed Icons (Symbols) and messages when using the LOW OHM and Continuity Functions

	Indicates the correct input terminal connectivity, the user should connect the test leads to the appropriate terminals indicated by colour.
	Low Battery (The icon will be flashing along with the beep sound).
	The resistance of the test leads are included in the test measurement.
	The resistance of the test leads are not included in the test measurement.

4.1.5. Displayed Icons (Symbols) and messages when using the RE function

	Indicates the correct input terminal connectivity, the user should connect the test leads to the appropriate terminals indicated by colour.
	Low Battery (The icon will be flashing along with the beep sound).
	The resistance of the test leads are included in the test measurement.
	The resistance of the test leads are not included in the test measurement.

4.1.5. Displayed Icons (Symbols) and messages in INSULATION Function

	Indicates the correct input terminal connectivity, the user should connect the test leads to the appropriate terminals indicated by colour.
	Low Battery (The icon will be flashing along with the beep sound).
	Indicates hi high voltage (125V, 250V, 500V or 1000V) at probe terminals. Use caution.

4.2. USING THE LOOP/PFC FUNCTION

1. Before you do a loop impedance test, use the zero adapter to zero the test leads or the mains cord.
2. Press and hold **F4** Button for more than two seconds until the "Ø" annunciator appears.
3. The tester measures the lead resistance, stores the reading in memory, and subtracts it from readings.
4. The resistance value is saved even when the power is turned off so it is unnecessary to repeat the operation each time you use the tester with the same test leads or mains cord.
5. You can select UL Voltage by pressing and hold **F3** Button for more than two seconds (25V or 50V).

Note: Be sure the batteries are in good charge condition before you zero the test leads.

4.2.1. Using the No Trip LOOP Measurement to be selected where the circuit is protected by an RCD whose rating is 30mA or above

1. Turn the rotary switch to the **LOOP/PFC** Position.
2. Connect the test leads.
3. If voltage of the L- PE on the lower left appears, the unit is ready to test.
4. Press the TEST Button when ready.
5. If noise appears during the No Trip Loop Measurement, the displayed value may not be accurate due to "mains" interference and the test should be repeated.
6. When carrying out the test from a 13A socket the points of contact are automatically selected by the plug top connection.



No Trip Loop Test Lead Connection

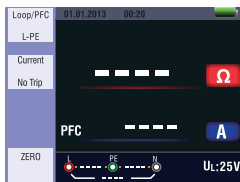

No Trip LOOP Standby Screen

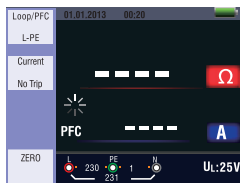

No Trip LOOP

4.2.2. LOOP/Pfc Function Menu Operation

Main Display

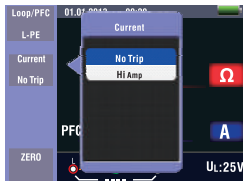

Menu Display

F1 Button: Pop-up and shut down Loop/PFC menu, shut down mode is activated when the user selects.

F2 Button: Pop-up and shut down Current menu, shut down mode is activated when the user selects.





F3 Button: None

F4 Button: Press the F4 button 3s, triggering zero function.

Up Button: Up menu to select the current active sub-options.

Down Button: Down menu to select the current active sub-options.

Enter Button: Confirm the user select mode.

1. When measuring is completed, impedance of L- PE and PFC (lf) value appears on the screen.
2. Press TEST Button if re-test is necessary.
3. When symbol from , , "", "", " " appears lower left corner, and if the voltage exceeds 260V, the measurement will not take place.

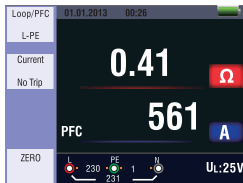

No Trip Measurement Completed

4.2.3. Using the Hi Amp LOOP Measurement to be selected where the circuit is not protected by the inclusion of an RCD

1. Turn the rotary switch to the **LOOP/PFC** Position.
2. Press **F2** Button to change from No Trip to Hi Amp.
3. Connect the test leads.
4. If voltage of the L- PE on the lower left appears, the unit is ready to test.
5. Press the **TEST** Button when ready.

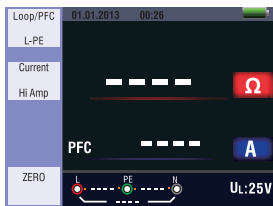

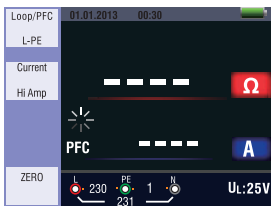

Hi Amp Loop Standby Screen

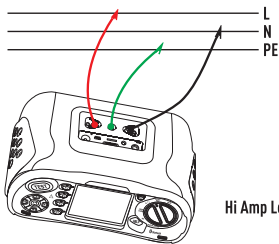

Hi Amp Loop to be used where no RCD is Present



Hi Amp Loop Test Lead Connection

6. When the measuring is complete the impedance of L-PE and PFC (f) value appears on the screen.
7. Press **TEST** Button if re-test is necessary
8. When symbol from , , "" appears lower left corner, and if the voltage exceeds 260V, the measurement will not take place

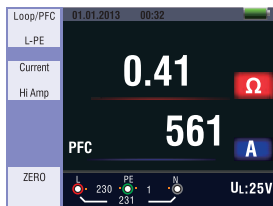

Hi Amp Loop Measurement Finished

4.2.4. Using the L-N Line Impedance Measurement

1. Turn the rotary switch to the **LOOP/PFC** Position.
2. Press **F1** Button to change from L-PE to L-N.
3. Connect the test leads.
4. If voltage of the L-PE on the lower left appears, the unit is ready to test.
5. Press the **TEST** Button when ready.

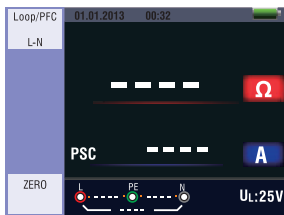

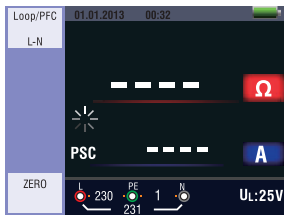

L-N Line Standby Screen

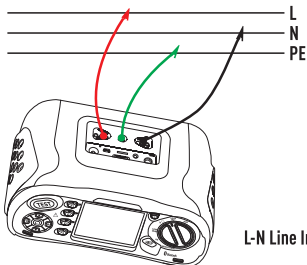

N Line Impedance When Measuring



L-N Line Impedance Test Lead Connection

6. When the measuring is complete the impedance of L-PE and PFC (f) value appears on the screen.
7. Press **TEST** Button if re-test is necessary
8. When symbol from , ,  appears lower left corner, and if the voltage exceeds 260V, the measurement will not take place

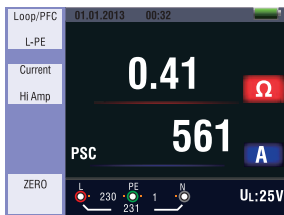

L-N Line Impedance Measurement Finished

4.3. Using The RCD Function

- You can select UL Voltage by pressing and hold F3 Button for more than two seconds (25V or 50V).
- UF value appears is the contact voltage on the screen.



RCD Standby Screen

Function Button Description

Button	1	2	3	4	5	6	7
F1	AUTO	RCD t Δ	RCD I Δ N				
F2	30mA	100mA	300mA	500mA	650mA	1A	10A
F3	AC G	AC S					
F4	0	180					

G: General (non-delayed) RCDs

S: Selective (Time-delayed) RCDs

Possible setup ratios depending on the RCD Trip Current

	10mA	30mA	100mA	300mA	500mA	650mA	1A
x1/2	0	0	0	0	0	0	0
x1	0	0	0	0	0	0	0
x2	0	0	0	0	0	X	X
X5	0	0	0	X	X	X	X
AUTO	0	0	0	X	X	X	X
RAMP	0	0	0	0	0	0	X

Maximum measurement Trip Time of the RCD (Complying to BS 61008 & 61009)

	1/2xI Δ N	I Δ N	2xI Δ N	5xI Δ N
General (Non-delayed) RCD	t Δ =Max.1999ms	t Δ =Max.500ms	t Δ =Max.150ms	t Δ =Max.40ms
Selective (Time-delayed) RCDs	t Δ =Max.1999ms	t Δ =Max.500ms	t Δ =Max.150ms	t Δ =Max.40ms

I Δ N: Trip-Out Current; t Δ : Trip-Out Time

 : Indicates that the thermal protection device has operated and therefore cannot make any measurements. Instrument must be allowed to cool for a period before tests can continue.

- Using the Functions activated by F1 Button.

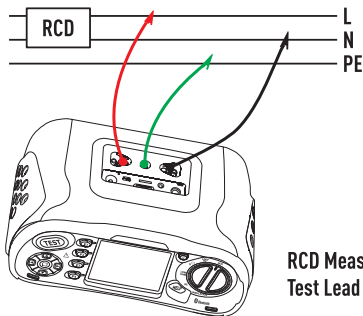

RCD Measurement
Test Lead Connection

4.3.1. Using the AUTO Mode

1. Turn the rotary switch to the **RCD** Position.
2. Initial screen is setup to the **AUTO**.
3. Using the **F2** and **F3** Button, select the rating and the type of the RCD.
4. Connect test leads.
5. If "___" from the lower right corner disappears and voltage of the L-PE on the lower left appears, the unit is ready to test (If N and PE test leads are reversed, the instrument will still carry out the test).
6. Press the **TEST** Button when ready.
7. Test will proceed it should not trip from x $\frac{1}{2}$ mode but will trip from the x1 0° mode, and indicate the trip time.
8. Reset RCD the unit will measure the Trip Time from the x1 180° mode.
9. Repeat for both x5 0° and x5 180° resetting RCD after each test.
10. Tests now complete see display for result.



RCD Auto Function Screen

4.3.2. Using the x $\frac{1}{2}$, x1 and x5 Manual Selection

1. Turn the rotary switch to the **RCD** Position.
2. Press **F1** and aspect Button from the AUTO to select x1/2, x1 and x5.
3. Using the **F2** and **F3** Button, select the RCD's trip current and type of the RCD (General/Selective).
4. Connect the test leads.
5. If " ___ " from the lower right corner disappears and voltage of the L-PE on the lower left appears, the unit is ready to test (If N and PE test leads are reversed, the instrument will still carry out the test).
6. Using the Selective RCDs with **F3** Button.
 - S: Selective (time-delayed) RCDs.
 - S (Selective (time-delayed)) RCDs will measure by delaying 30 seconds and then stream the current (will display 30 seconds during the time of the delay).
 - AC RCD streams current in r.m.s. value which has the sine wave form.
7. Using the Selective 0° and 180° with **F4** Button.
8. Press the **TEST** Button when ready.
9. Record slowest time.

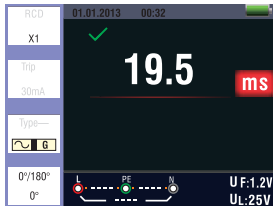

x1 Mode Measuring Screen

4.3.3. Using the RAMP Function

1. Turn the rotary switch to the **RCD** Position.
2. By pushing the **F1** Button select **RAMP** from **AUTO**.
3. Using the **F2** and **F3** Button, select the RCD's trip current and type of the RCD.
4. Using the Selective 0° and 180° with **F4** Button.
5. Press **TEST** Button the test current ramps up from 3mA to 33mA in 3mA stages.
6. The RCD should operate approximately 21mA for it to be in Compliance.

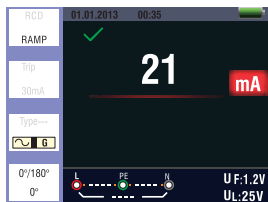

RCD Ramp Measuring Screen

4.3.4. RCD Function Menu Operation

Main Display

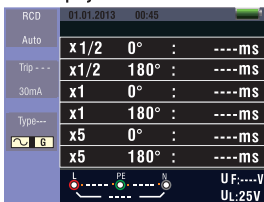

RCD AUTO

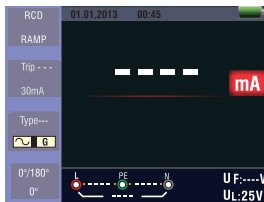

Other

Menu Display

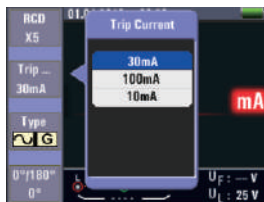

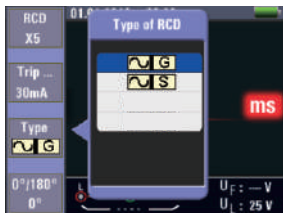

- F1 Button: Pop-up and shut down RCD time/trip menu, shut down mode is activated when the user selects.
- F2 Button: Pop-up and shut down Trip Current menu, shut down mode is activated when the user selects.
- F3 Button: Pop-up and shut down Type of RCD menu, shut down mode is activated when the user selects.
- F4 Button: Pop-up and shut down Type of 0°/180° menu, shut down mode is activated when the user selects.
- Up Button: Up menu to select the current active sub-options.
- Down Button: Down menu to select the current active sub-options.
- Enter Button: Confirm the user select mode.

4.4. Using the Voltage Function

WARNING: Do not use on a circuit whose voltage either L-L or L-N exceeds 550V Measuring the Voltage and Frequency.

1. Connect the test lead input terminal.
2. Turn the rotary switch to the Voltage Position.
 - Do not attempt to measure when the input voltage is above 500VAC.
 - Value at the top right hand corner represents the Voltage, and the value in the right hand center represents the frequency.
 - The display will appear without the **TEST** Button operated.

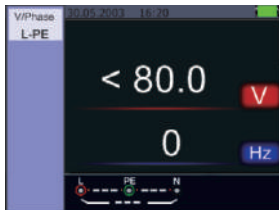

Standby Screen for the Voltage and Frequency

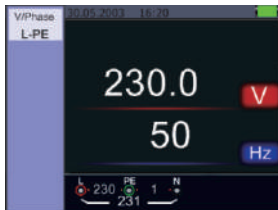

Screen While Measuring Voltage and Frequency

4.5. Using the Phase Sequence Function

1. Turn the rotary switch to the **Voltage** Position.
2. Press F1 Button to make symbol is displayed.
3. Connect the test leads L1, L2, L3.
4. When the instrument is energized the sequence will be displayed automatically.



Initial Screen of the
Phase Sequence Measurement

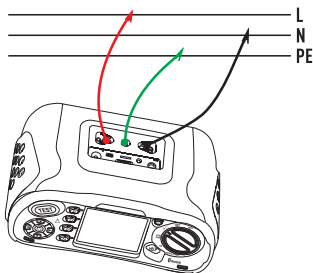

Phase Sequence Test Lead Connection

- When the line conductors are connected in the correct sequence 1.2.3 and the symbol will appear as the Figure.
- However connected in the wrong sequence, 2.1.3 and the circle symbol will change to the symbol displayed below.

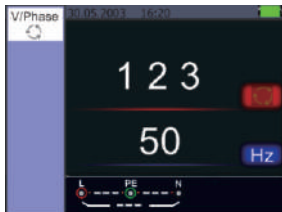

Phase Sequence Screen
When connected in clockwise direction

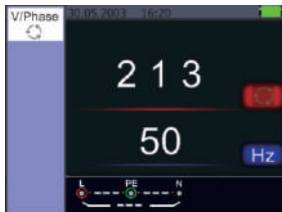

Phase Sequence Screen
When connected in counter-clockwise manner

4.6. Voltage/Phase Function Menu Operation



Main Display

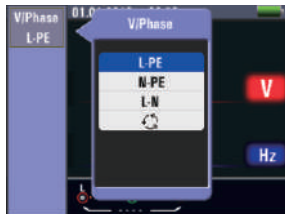

Menu Display

Fl Button: Pop-up and shut down Voltage/Phase menu, shut down mode is activated when the user selects.

F2 Button: None

F3 Button: None

F4 Button: None

Up Button: Up menu to select the current active sub-options.

Down Button: Down menu to select the current active sub-options.

Enter Button: Confirm the user select mode

4.7. Using the Insulation Function

4.7.1. Insulation Function/Menu Operation



Main Display



Menu Display

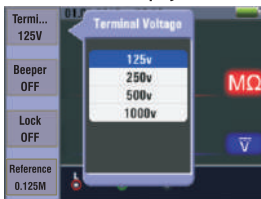

Menu Display

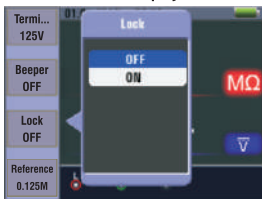

Menu Display

- F1 Button: Pop-up and shut down Insulation Voltage Selection menu, shut down mode is activated when the user selects.
- F2 Button: Pop-up and shut down Insulation Beeper menu, shut down mode is activated when the user selects.
- F3 Button: Pop-up and shut down Insulation Auto Lock menu, shut down mode is activated when the user selects.
- F4 Button: Pop-up and shut down Insulation Megaohm Reference menu, shut down mode is activated when the user selects.
- Up Button: Up menu to select the current active sub-options.
- Down Button: Down menu to select the current active sub-options.
- Enter Button: Confirm the user select mode.

4.7.2. Insulation Resistance Display/Switch and Terminal Settings

WARNING: Measurements should only be performed on de-energized circuits.

1. Turn the rotary switch to the INSULATION Position.
2. Use the L and N (Red and Black) terminals for this test.
3. Press F4 Button and set limit value (optional).
4. Use the F1 Button to select the test voltage, most insulation testing is performed at 500V, but observe local test requirements.
5. Press and hold TEST Button until the reading settles and the tester beeps.

Note:

- Testing is inhibited if voltage is detected in the line.
- The primary (Upper) display shows the insulation resistance.
- The secondary (Lower) display shows the actual test voltage.
- For normal insulation with high resistance, the actual test voltage (UN) should always be equal to or higher than the programmed voltage, if insulation resistance is bad, the test voltage is automatically reduced to limit the test current to safe ranges.

4.8. Using the RE Function

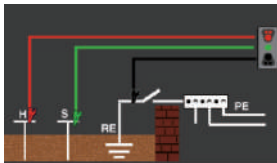

4.8.1. Earth Resistance Display/Switch and Terminal Settings

- The earth resistance test is a 3-wire test consisting of two test stakes and the earth electrode under test.

- This test requires an accessory stake kit. Connect as shown in figure.
- Best accuracy is achieved with the middle stake at 62% of the distance to the far stake.
- The stakes should be in a straight line and wires separated to avoid mutual coupling.
- The earth electrode under test should be disconnected from the electrical system when conducting the test.
- Earth resistance testing should not be performed on a live system.

4.8.2. To Measure Earth Resistance

1. Turn the rotary switch to the RE Position.
2. Press and release TEST Button, wait for the test to complete.
 - The primary [upper] display shows the earth resistance reading.
 - The Test Current will be displayed in the secondary display.
 - If Voltage detected between the test rods greater than 10V, the test is inhibited.

4.8.3. RE Function Menu Operation

- F1 Button: None
 F2 Button: None
 F3 Button: None
 F4 Button: Press the F4 Button 3s, triggering zero function.
- Up Button: None
 Down Button: None
 Enter Button: None



Main Display

4.9. Using the LOW OHM Function

- A continuity test is used to verify the integrity of connections by making a high resolution resistance measurement.
- This is especially important for checking Protective Earth connections.



4.9.1. LOW OHM Function Menu Operation

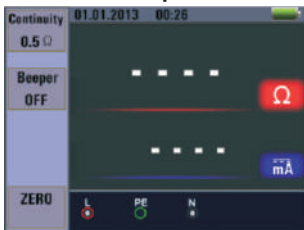

Main Display

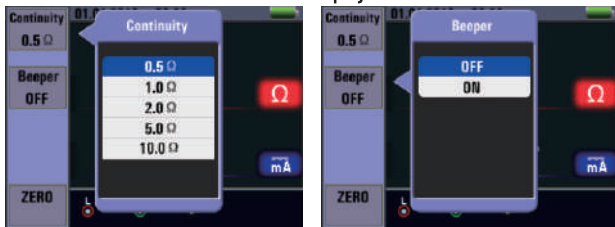

Menu Display

- F1 Button: Pop-up and shut down LOW OHM Continuity menu, shut down mode is activated when the user selects.
- F2 Button: Pop-up and shut down LOW OHM Beeper menu, shut down mode is activated when the user selects.
- F3 Button: None
- F4 Button: Press the F4 button 3s, triggering zero function.
- Up Button: Up menu to select the current active sub-options.
- Down Button: Down menu to select the current active sub-options.
- Enter Button: Confirm the user select mode

To Measure Continuity

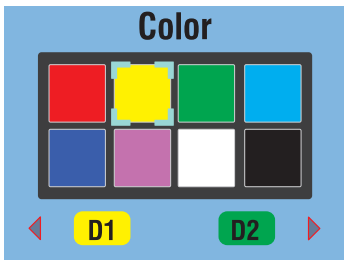

1. Turn the rotary switch to the **RLO** Position.
2. Use the L and N [Red and Black] terminals for this test.
3. Before making a continuity test, short the ends of the probes together and press the **ZERO** Button, after performing test leads compensation compensated test leads indicator is displayed.

- Press and hold TEST until the reading settles.
- If the continuity beeper is enabled, press the **F1** Button to set high limit resistance value, the tester beeps continuously for measured values less than high limit resistance and there is no stable reading beep for measured values greater than high limit resistance.







5. Menu





- Press the "◀" and "▶" Button to select the System Settings, Data Record or Run Settings.
- Then press the "□" Button to enter.

Items	Menu
	System Settings
	Data Record
	Run Settings

6. System Settings

- Press the "▲" and "▼" Button to select the Items.
- Then press the "□" Button to enter.

Items	Menu
	Languages
	Date/Time
	TV
	Memory

Items	Menu
	Auto Screen Off
	Auto Power Off
	System Default Settings
	System Upgrade

6.1. Languages

- Press the "▲" and "▼" Button to select the Language.
- Then **ESC** Button to esc and save the select the Language.

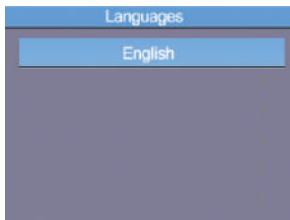

6.2. Date/Time

- Press the "▲" and "▼" Button to select the date or time, then press the "□" Button to enter.
- Press the "▲" and "▼" Button to adjust the value, press the "◀" and "▶" Button to select the Items.
- Press the **ESC** Button to esc and save.

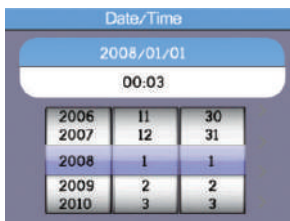

6.3. TV

- Press the "▲" and "▼" Button to select the output time.
- Then press the "□" Button to enter.

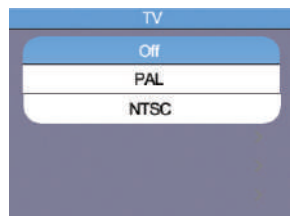

6.4. Memory

- Press the "▲" and "▼" Button to select the Working Space or Format.
- Then press the "□" Button to enter, press the **ESC** Button to esc and save.

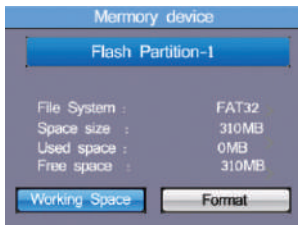

6.5. Auto Screen Off

- Default 3 Minutes.
- Press the "▲" and "▼" Button to select the Working Space or Format.
- Press **ESC** Button to esc and save the select the time.

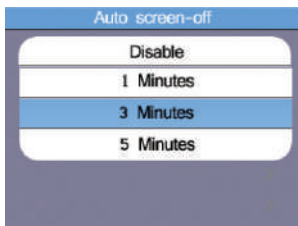

6.6. Auto Power Off

- Default 10 Minutes.
- Press the "▲" and "▼" Button to select the Auto power-off time.
- Press **ESC** Button to esc and save the select the time.

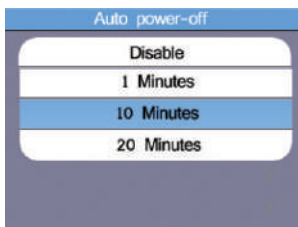

6.7. System Default Settings

- Then press the "□" Button to enter
- Press the "▲" and "▼" Button to select whether you want to Reset.



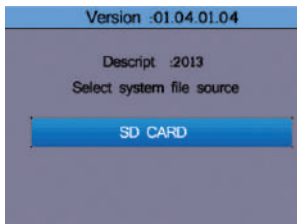

6.8. System Upgrade

- Then press the "□" Button to enter



7. Run Settings

- Press the "▲" and "▼" Button to select the items, then press the "□" Button to enter

Items	Menu
	On or off the Bluetooth
	Data Record
	Datalog

7.1. Bluetooth

- Press the "◀" and "▶" Button to select the on or off bluetooth.
- Then **ESC** Button to esc and save.



Off the Bluetooth



On the Bluetooth

Note: Bluetooth Connect:

1. Turn on the Bluetooth function on the instrument using Menu Button
2. Turn on the Bluetooth of the Smartphone, press the **Meterbox Pro** icon and enter into the home interface. Then press **Connect Device** icon on the home interface, Bluetooth device name will appear.
3. Touch the device name listed in Bluetooth devices list to connect the meter.

Detailed information about **Meterbox Pro** available on the APP help file.

Meterbox Pro for Android: Please search in Google Play with keyword Meterbox Pro, download and run.

Meterbox Pro for iOS: Please search in the Apple Store with keyword Meterbox Pro, download and run.

7.2. Data Record

- Press the "◀▶▲▼" Button to select the characters press
- Press the "□" Button to enter characters.

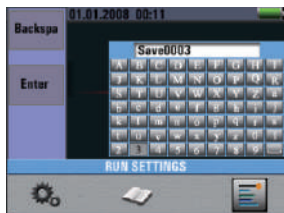

Note: Data recording shortcuts, press the left button.

Items	Menu
F1 Button	Backspa
F2 Button	Enter Data Record
□	Enter characters



7.3. Datalog

- Press the "▲" and "▼" Button to select the items.
- Press the "◀" and "▶" Button to set.

Items	Menu
	On or off the Datalog
	/Set Datalog time (Unit: Second)

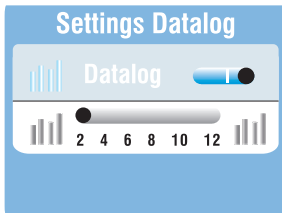

8. Data Record

- Press the "▲" and "▼" Button to select the data record file.
- Then press the "□" Button to enter.



8.1. Delete Files

- Press **Help/Delete** Button to menu.
- Press the "▲" and "▼" Button to the Yes or No.
- Then press the "□" Button to execute.

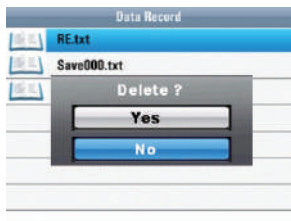

8.2. Data Record Preview

- Press the "▲" and "▼" Button to select the items.
- Press the "◀" and "▶" Button to set.
- Then press the "□" Button to enter.
- Press the ESC Button to esc data record preview.

F1 Button: None
F2 Button: None
F3 Button: None
F4 Button: None
Up Button: Turned up view log data
Down Button: Turned down view log data

Left Button
Right Button
Enter Button: Menu

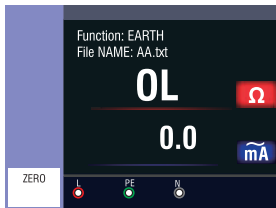

Main Display

8.3. Menu

8.3.1. Data Record

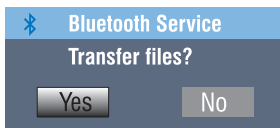

8.3.2. Datalog

- Press the "▲" and "▼" Button to select the items.
- Then press the "□" Button to enter.

F1 Button: None
F2 Button: None
F3 Button: None
F4 Button: None
Up Button: Select up
Down Button: Select down
Left Button: None
Right Button: None
Enter Button: Confirm the user select mode

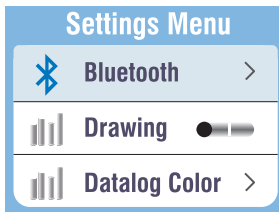

8.3.3. Bluetooth

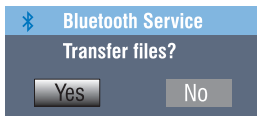

8.4. Drawing

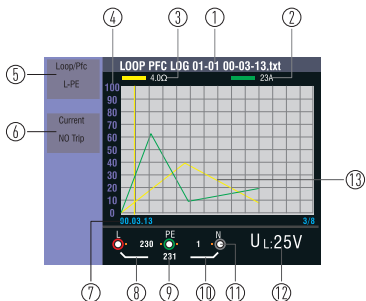

No.	Annunciator	Meaning
1	File Name	File Named: Month/Day File Type LOOP PFC LOG 01-01 00-03-13.txt Function Hours/Minutes/Seconds
2	Primary display & measurement units.	
3	Primary display & measurement units.	
4	Coordinate	
5	Function	
6	Function	
7	Hours/Minutes/Seconds	Record time
8	L-FE Value	
9	L-N Value	
10	FE-N Value	
11	Arrows above or below the terminal indicator symbol indicate reversed polarity. Check the connection or check the wiring to correct.	
12	UF Value	
13	Main display curve	

8.5. Datalog Color

WARNING: Measurements should only be performed on de-energized circuits.

WARNING: Measurements may be adversely affected by impedances or parallel circuits or transient currents.



MAJOR TECH (PTY) LTD

South Africa

 www.major-tech.com

 sales@major-tech.com

Australia

 www.majortech.com.au

 info@majortech.com.au

